

DE45F4

LIQUID-COOLED DIESEL GENERATOR

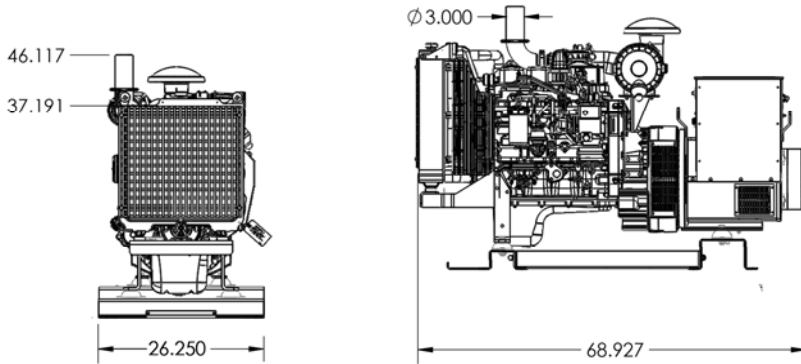

Est. 1925



Weight: 1750 lbs

Powered by ...



N45 SM1
4.5 Liter
Turbocharged

SPECIFICATIONS SUBJECT TO CHANGE WITHOUT NOTICE ***VERS DE4514 7-15

Electrical Output 45kW Standby/40kW Prime

Output Voltage – 60Hz	kW	kVa	Amperes	CB Size
*120/240, 1-phase, 1.0 pf	40	40	166	175
120/208, 3-phase, 0.8 pf	45	56	156	150
120/240, 3-phase, 0.8 pf	45	56	135	125
277/480, 3-phase, 0.8 pf	45	56	68	70

*SINGLE PHASE RATING AT 125° HEAT TEMPERATURE RISE

EXPERIENCED DESIGN

- WINPOWER HAS BEEN BUILDING INDUSTRIAL GENERATORS SINCE 1925
- BUILT STRONGER TO LAST LONGER
- RUBBER ENGINE AND GENERATOR VIBRATION ISOLATION MOUNTS
- EXPERIENCED ENGINEERING GROUP
- EVERY UNIT IS 100% LOAD TESTED TO ENSURE QUALITY, WE DO NOT USE STATISTICAL SAMPLING
- ALL INVENTORY IS STORED INDOORS UNTIL IT SHIPS
- MADE IN THE USA

GENSET CONTROL

- KEY START WITH ENGINE PREHEAT
- STANDARD SAFETY FEATURES/SHUTDOWNS:
 - LOW OIL
 - OVER TEMPERATURE
 - OVER SPEED

GENERAL INFORMATION

Derating Factors

TEMPERATURE > 104°F 3% PER 10°F
 ALTITUDE 3% PER 1000 FT
 PRIME POWER 10%

Fuel Consumption

100% LOAD 3.975 GAL/HR
 50% LOAD 2.35 GAL/HR

Limited Warranty

Winpower warrants its product from material defects for a period of one year/1000 hrs. Iveco warrants the engine for prime power generator applications for 1 year/unlimited hours.

ENGINE SPECIFICATIONS

MAKE FPT
 MODEL N45 SM1
 EPA TIER III
 TYPE DIESEL
 KWM @ 1800 RPM-STANDBY 57 KWM
 SPEED GOVERNOR MECHANICAL
 CYLINDERS 4
 TOTAL DISPLACEMENT 4.5L
 ASPIRATION TURBOCHARGED
 OIL & FILTER REPLACEMENT 600 HRS
 EXHAUST OUTLET (MUFFLER SHIPS LOOSE) 3”
 ELECTRICAL SYSTEM (NEGATIVE GROUND) 12 VDC
 ALTERNATOR (BOSCH) 90 AMPS
 STARTER BOSCH

ALTERNATOR SPECIFICATIONS

RATING (105/40°C) STANDBY
 TYPE 4 POLE – REVOLVING FIELD
 SPEED 1800 RPM
 INSULATION SYSTEM CLASS H
 SINGLE PHASE 12 LEAD
 THREE PHASE 12 LEAD
 PITCH 2/3
 THD <5%
 COUPLING FLEXIBLE DISC
 BEARINGS (MAINTENANCE FREE) 1
 AUTOMATIC VOLTAGE REGULATION +/- 1.5%
 SINGLE PHASE RATING 1.0pf
 THREE PHASE RATING 0.8pf